

NA-K 6000 B

(45.601)

Voltage	(V)	400	Water capacity	390
Motor	(kW)	7,5	Water connection	G ¾"
Current (400V/50Hz)	(A)	14,4	Intake diameter	(mm) 280/300
Fuse	(A)	32	Weight (without water)	(Kg) 530
max. neg. pressure	(Pa)	3.600	Sludge tank	(Liter) 50
max. airflow	(m ³ /h)	5.150	Dimensions (L x B x H)	(mm) 950 x 950 x 3.530

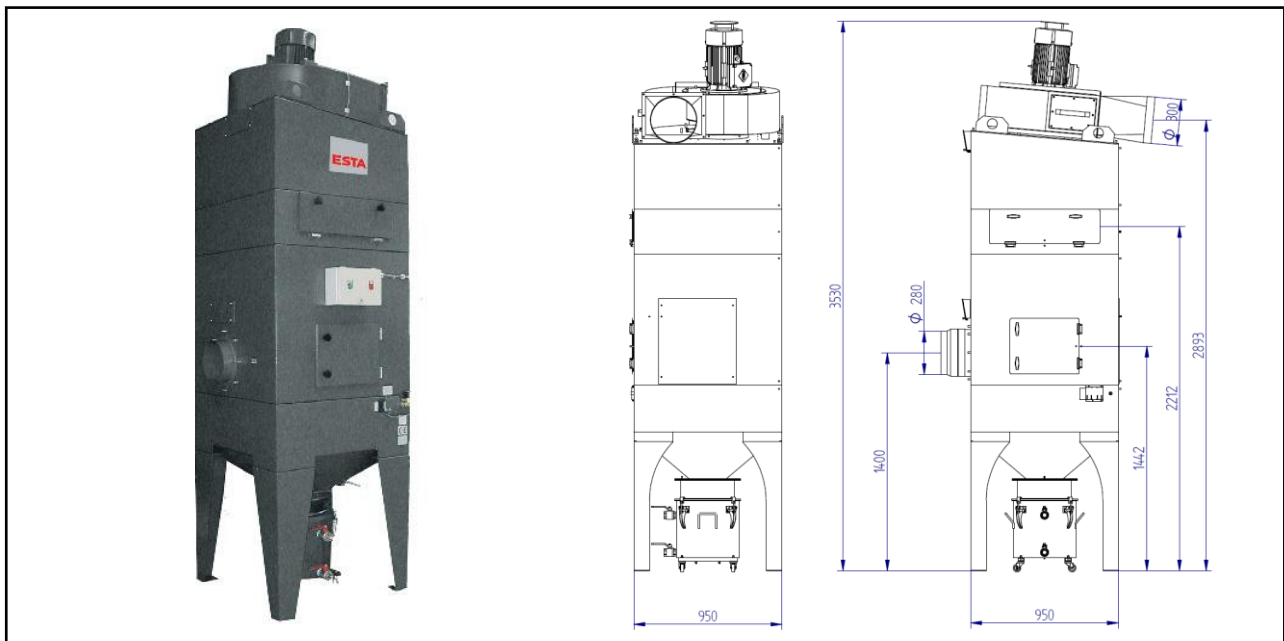

ESTA PLUS

Application range:

- Extraction of aluminium dust
- Dust extraction at individual or multiple workstations of adhesive and moistly dusts, especially metallic dusts that are sparks generating
- As central exhaust station with intercepting pipe and several extraction points

Your benefits at a glance

- High suction power for adhesive and moistly dusts
- Ideal solution for sparks generating applications

Characteristics:

- Partially made of stainless steel, epoxy resin based
- interior coating
- Integrated control cabinet

Custom design/optional:

- with special painting

State of the art: 45601-51-01 Subject to change without notice! For remaining questions please do not hesitate to contact us..